

**84 Link Inverse Multiplexer for ATM (IMA) / UNI PHY**

**FEATURES**

**IMA**

- Supports up to 84 T1 or 63 E1 links and up to 42 IMA groups with 1 to 32 links/group.
- Link and Group State Machines implemented on-chip requiring no real time software in the data path.
- Fully compliant with the ATM Forum Inverse Multiplexer for ATM (IMA) 1.1 specification and backward compatible to IMA 1.0.
- Supports both independent transmit clock (ITC) and common transmit clock (CTC) modes.
- Supports all IMA Group Symmetry modes: Symmetric/Asymmetric configuration and operation.
- Differential delay tolerance of 279 ms (for T1 links) and 226 ms (for E1 links).
- Performs IMA differential delay calculation and synchronization.
- Provides programmable limit on allowable differential delay and minimum number of links per group.
- Performs ICP and stuff-cell insertion and removal.
- Supports IMA frame length (M) equal to 32, 64, 128, or 256.
- Provides IMA layer statistic counts and alarms for support of IMA Performance and Failure Alarm Monitoring and MIB support.
- Provides per link counters for statistics and performance monitoring.

**UNI**

- Supports up to 84/63 ATM over T1/E1 UNIs or 3 ATM over DS3 UNIs.
- Each T1/E1 link is software configurable as either a UNI or part of an IMA group.
- Performs receive cell Header Error Check (HEC) checking and transmit cell HEC generation.
- Optionally supports receive cell payload unscrambling and transmit cell payload scrambling.
- Provides TC layer statistics counts and alarms for MIB support.

**ATM OVER FRACTIONAL T1/E1**

- Supports up to 32 ATM over Fractional T1/E1 UNIs over the clock/data interface, compliant with the ATM Forum AF-PHY-0130.00 specification.

**LINE INTERFACE**

- Supports a 19.44 MHz Scalable Bandwidth Interconnect (SBI) bus interface for seamless interconnect to the PM8315 TEMUX and PM8316 TEMUX-84.
- SBI supports three Synchronous Payload Envelopes (SPE) where each SPE can carry up to 28 T1s, 21 E1s, or one unchannelized DS3 stream.
- Supports up to 32 T1, E1, G.SHDSL or unchannelized links via 2-pin line interfaces.

**UTOPIA / ANY-PHY INTERFACE**

- Supports 8- and 16-bit UTOPIA L2 and Any-PHY cell interfaces at clock rates up to 52 MHz.
- Any-PHY transmit slave appears as an 84 port multi-PHY. The PHY-ID of each cell is identified using in-band addressing.

- Any-PHY receive slave appears as a single device. The PHY-ID of each cell is identified using in-band addressing.
- UTOPIA L2 transmit and receive slave appears as a 31-port multi-PHY.
- UTOPIA L2 receive slave can also appear as a single port with the logical port provided as a prepend.

**LOOPBACK AND DIAGNOSTICS**

- Supports UTOPIA Side Loopback.
- Supports Line Side Loopback.
- Supports per group ICP cell trace capability.

**SOFTWARE**

- The S/UNI-IMA device driver, written in ANSI C, provides a well-defined API and low level utility functions for diagnostics and debugging purposes
- Software wrappers are used for RTOS-related functions making the S/UNI-IMA device driver portable to any Real Time Operating System (RTOS) environment.

**BLOCK DIAGRAM**

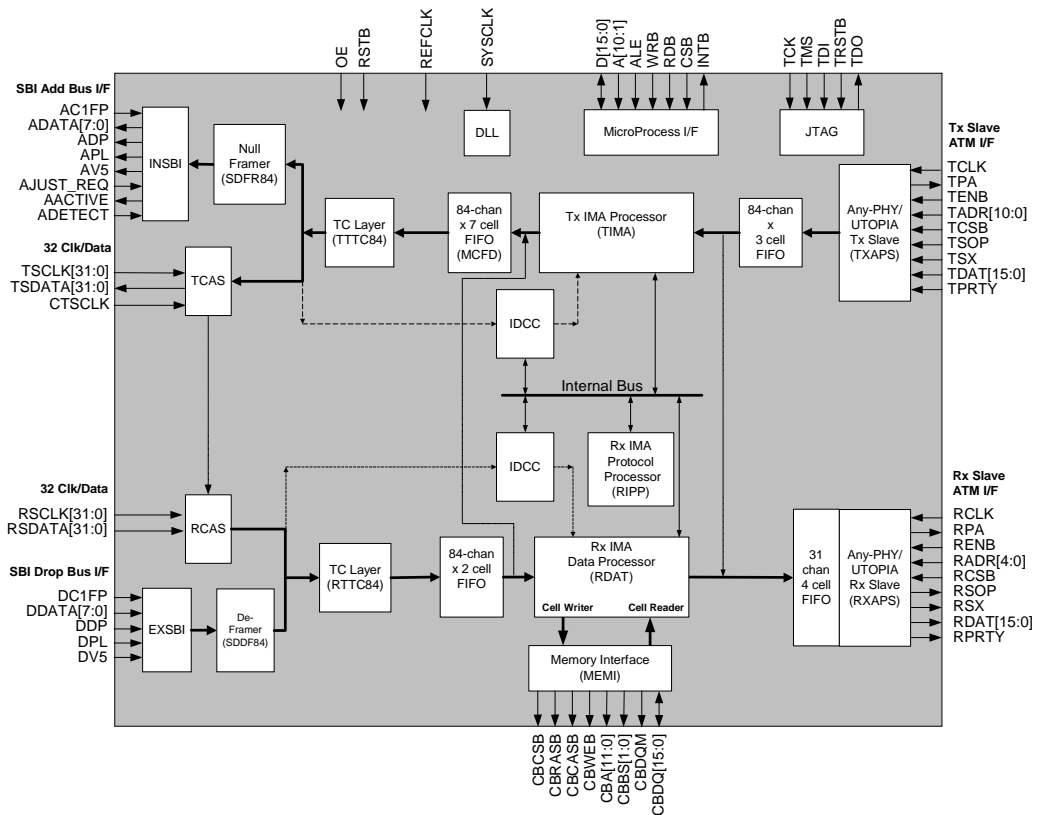

**84 Link Inverse Multiplexer for ATM (IMA) / UNI PHY**

**GENERAL**

- 16-bit interface for 1M x 16 or 4M x 16 SDRAM, depending on the differential delay tolerance.
- Provides a 16-bit microprocessor interface for configuration, statistics gathering and Link and Unit Management.
- Provides a standard 5-pin P1149 JTAG port.
- Low-power 1.8 V CMOS with TTL-compatible I/O.
- 416-pin plastic ball grid array (PBGA) package.

**APPLICATIONS**

- Multiservice Switches.
- Optical Access Switches.
- Wireless Basestation Controllers.

**TYPICAL APPLICATIONS**

**ATM MULTISERVICE SWITCH**

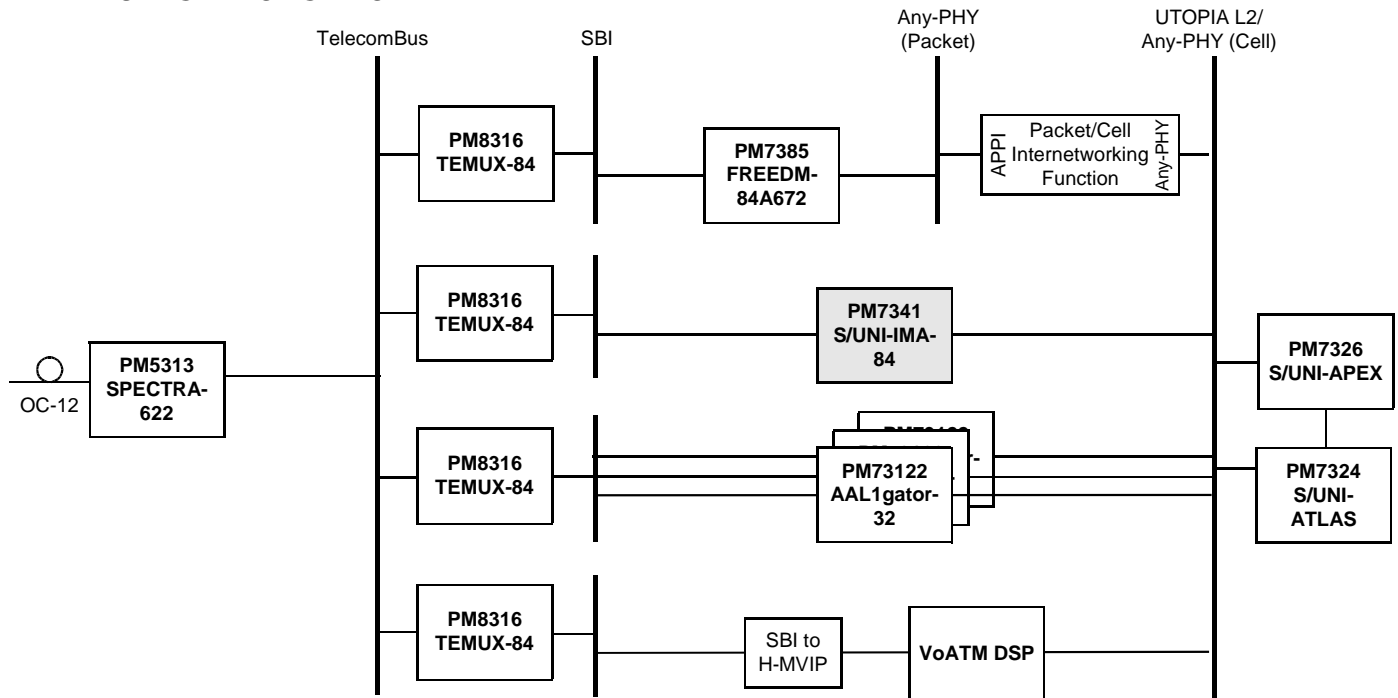

**WIRELESS BASESTATION CONTROLLER**

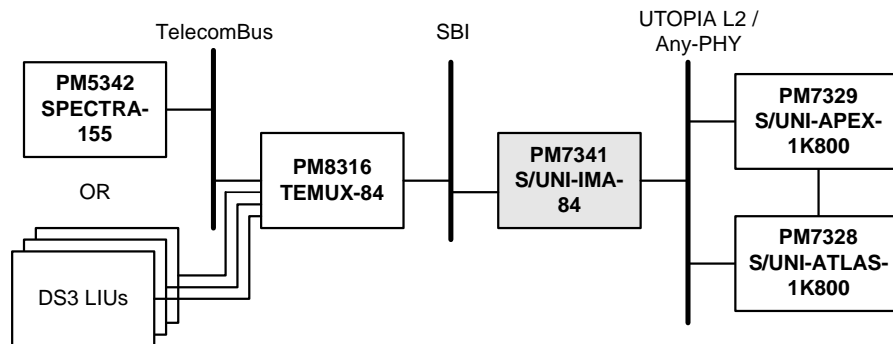

Head Office:  
 PMC-Sierra, Inc.  
 8555 Baxter Place  
 Burnaby, B.C. V5A 4V7  
 Canada  
 Tel: +1.604.415.6000  
 Fax: +1.604.415.6200

To order documentation,  
 send email to:  
 document@pmc-sierra.com  
 or contact the head office,  
 Attn: Document Coordinator

All product documentation is available  
 on our web site at:  
<http://www.pmc-sierra.com>  
 For corporate information,  
 send email to:  
 info@pmc-sierra.com

PMC-2001522 (p4)  
 © Copyright PMC-Sierra, Inc. 2001. All  
 rights reserved. October 2001.  
 S/UNI is a registered trademark of  
 PMC-Sierra, Inc.  
 SBI, AAL1gator, FREEDM, SPECTRA,  
 AAL1gator, COMET-QUAD, and Any-PHY  
 are trademarks of PMC-Sierra, Inc.